

Vickers®

Vane Motors



High Speed Vane Motors

M2U, M2-200 and 25M-50M Series for Industrial Equipment

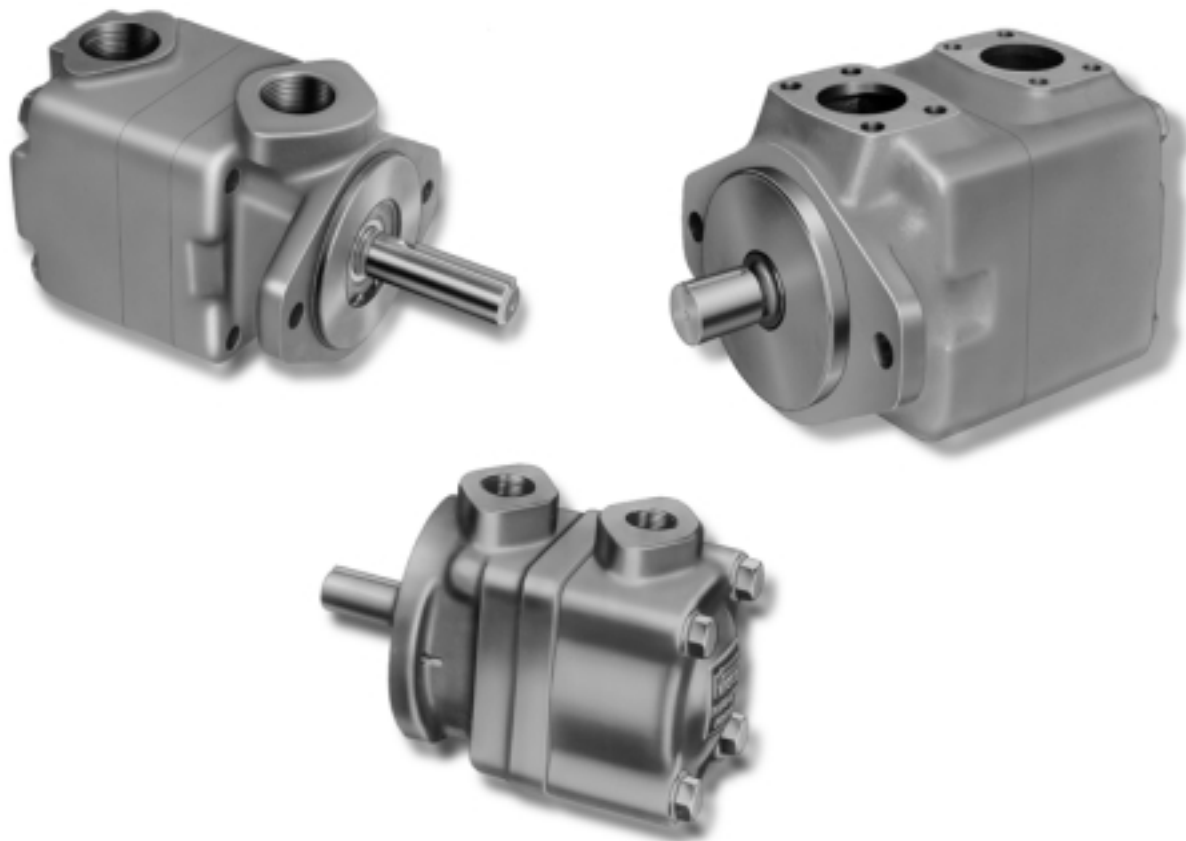

VICKERS

Revised 4/98

Introduction

M2U and M2-200 Motors

General Information

These motors offer a combination of low cost, pressures to 138 bar (2000 psi), speeds to 2800 r/min, torques of 2.0, 2.8 or 4.0 Nm/6.9 bar (18, 25 or 35 lb. in./100 psi), flange or foot mounting, and choice of port locations.

Rotation

M2U motors operate in one direction only, and rotation must be specified when ordering. Shaft rotation of M2-200 motors can be reversed simply by reversing the direction of flow through the motor ports.

Low Speed Capability

Minimum speed can vary between 50 and 100 r/min, depending upon motor size and characteristics of the driven load.

Characteristics

An economical, efficient and compact means of applying variable speed, rotary hydraulic power, these motors have variable horsepower (constant torque) characteristics. They can be stalled

under load without damage when protected by a relief valve.

Indirect Drive Capability

Rugged two-bearing construction permits motors to be used in direct or indirect drive installations. Indirect drive applications require approval by Vickers Engineering Department.

25M - 50M Motors

General Information

These high speed, high pressure motors offer a choice of 12 torque ratings from 4,7 to 33,9 Nm/6,9 bar (42 to 300 lb. in./100 psi); speeds from 400 to 3600 r/min continuous and 4000 r/min intermittent; pressures to 155 bar (2250 psi) continuous and 172 bar (2500 psi) intermittent; reversible shaft rotation; flange or foot mounting.

Rotation

Shaft rotation can be reversed simply by reversing the direction of flow through the motor ports. When properly protected by valves, the motor may be used for rapid cycle reversing or stalled without damage.

Low Speed Operation

Minimum speed is normally 100 r/min. Lower speeds are obtainable, depending upon torque requirements and the nature of the load.

Replaceable Cartridge

Rotary motion is developed within the drive cartridge which consists principally of a cam ring, rotor, ten vanes, and two pressure plates. The cartridge is bolted together so parts can be serviced separately or as an assembly. Replaceable cartridges permit motor overhauls in just 10 minutes. A cartridge can be replaced without removing the unit from the machine, and usually without disconnecting hydraulic lines.

Series Operation

25M - 50M motors are suited to series applications. Inlet and outlet ports can be pressurized simultaneously without affecting service life or operating smoothness.

Indirect Drive Capability

Double-row bearings are available for increased radial load capacity. Indirect drive applications require approval by Vickers Engineering Department.

Features and Benefits

M2U and M2-200 Motors

Low-wear Design

Two internal inlet chambers are diametrically opposed as are two outlet chambers. This construction eliminates bearing loads resulting from pressure, a major cause of wear in designs without this feature.

Installation Flexibility

The motor's cover can be assembled in different positions with respect to the body. To change the relative location of the ports, it is necessary only to remove four cover bolts and rotate the cover to the desired position. This allows optimum positioning to suit connecting piping.

High Efficiency

Optimum running clearances and hydraulic balance assure sustained high efficiency over the life of the motor.

Smooth Operation

Inertia of rotating parts is low ... parts are symmetrical, providing dynamic balance and freedom from vibration.

25M - 50M Motors

High Efficiency

A unique dual pressure plate design results in low internal leakage and overall operating efficiencies up to 90%. Efficiency varies with motor size, pressure, speed, and fluid viscosity and temperature.

Mounting Flexibility

The motor's cover can be assembled in four positions with respect to the body. Changing port positions is accomplished by simply rotating the cover, and the cartridge which is pinned to the cover, in 90° increments, thus providing the optimum mounting for connecting piping.

Easy to Service

The drive cartridge is accessible by removing the motor's cover and can normally be replaced in ten minutes without removing the motor from the machine. The torque capability of motors within the same model series can be changed by changing the cartridge or cam ring.

Low-wear Design

25M - 50M motors are hydraulically balanced to reduce wear and heat-producing friction. All internal inlet chambers are equally and diametrically opposed. As a result, pressure induced radial loads are balanced. Shaft bearings only have to carry external loads so wear is greatly reduced.

Proven Reliability

For more than two decades, the reliability of these high performance motors has been field proven on a variety of machinery applications.

Table of Contents

M2U and M2-200 Motors

Specifications & Model Codes 4

M2U Performance Curves 5

M2-200 Performance Curves 7

M2U Installation Dimensions 8 & 10

M2-200 Installation Dimensions 9 & 10

25M - 50M Motors

Specifications & Model Codes 11

25M Performance Curves 12

35M Performance Curves 14

45M Performance Curves 16

50M Performance Curves 19

25M Installation Dimensions 21 & 25

35M Installation Dimensions 22 & 25

45M Installation Dimensions 23 & 25

50M Installation Dimensions 24 & 25

Foot Mounts

..... 26

Application and Service Information

..... 28

Motor Characteristics 27

Mounting Dimensions 27

Drives 27

Circuitry Requirements 27

Fluids 28

Application Guidance 28

Service Information 28

Fluid Cleanliness 29

M2U and M2-200 Series

Specifications

Model series	Torque Nm/6,9 bar (lb in/100 psi)	Displacement cm ³ /r (in ³ /r)	Maximum speeds & pressures	Approx weight kg (lb)
M2U	2,0 (18)	21,6 (1.32)	2800 r/min @ 138 bar (2000 psi)	7,7 (17)
	2,8 (25)	25,4 (1.55)	2500 r/min @ 138 bar (2000 psi)	
	4,0 (35)	37,5 (2.29)	2000 r/min @ 138 bar (2000 psi)	
M2-200	2,8 (25)	24,7 (1.51)	2200 r/min @ 138 bar (2000 psi)	9,5 (21)
	4,0 (35)	35,4 (2.16)	1800 r/min @ 121 bar (1750 psi)	

Model Codes

M 2 U - 1 S 35 S - 1 C 10 S60 L

1	Vane motor	7	Outlet port S – 1-5/16 – 12 st. thd.	10	Design Subject to change. Installation dimensions remain the same for designs –10 through –19.
2	Series	8	Shaft type 1 – Straight keyed 3 – Threaded 11 – Splined	11	Special suffix S60 – High pressure shaft seal 3,4 bar (50 psi) continuous Omit if not required
3	Uni-directional rotation	9	Outlet position (Viewing cover end) A – Outlet port opposite inlet C – Port connections inline	12	Rotation L – Left hand (counterclockwise) Omit for right hand (clockwise)
4	Mounting 1 – 2-bolt flange				
5	Inlet port S – 1-5/16 – 12 st. thd.				
6	Ring size – torque (lb in/100 psi) 18, 25 and 35				

M 2 - 2 1 0 - 35 - 1 C - 13 - S2

1	Vane motor	7	Shaft type 1 – Straight keyed 3 – Threaded 6 – Straight keyed (stub) 11 – Splined	9	Design Subject to change. Installation dimensions remain the same for designs –10 through –19.
2	Series (bi-directional rotation)	8	Cover position (Viewing cover end) A – Cover port opposite body port B – Cover port 90° CCW from body port C – Port connections in line D – Cover port 90° CW from body port	10	Special suffix S2 – Pressured vane extension (5,2 bar (75 psi) minimum pilot pressure required) S60 – High pressure shaft seal 3,4 bar (50 psi continuous) S61 – BSPF metric ports Omit if not required
3	Series frame size				
4	Porting 1 – 3/4 NPT both ports				
5	Mounting 0 – 2-bolt flange 4 – Foot mounting				
6	Ring size – torque (lb in/100 psi) 25 and 35				

M2U Series

Typical Performance

Performance Constants:

Oil temp. 49°C (120°F), viscosity
32 cSt (150 SUS) @ 38°C (100°F)

18 LB. IN. RING

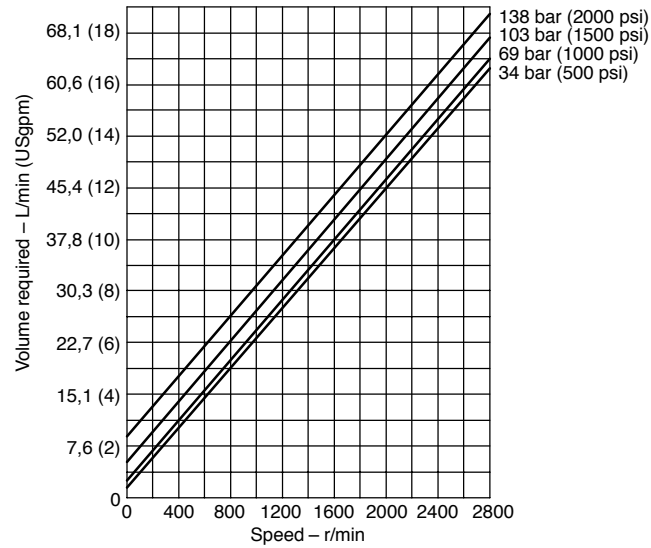

25 LB. IN. RING

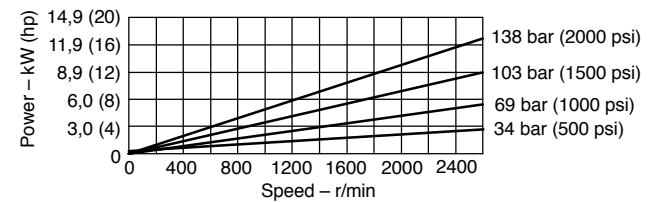
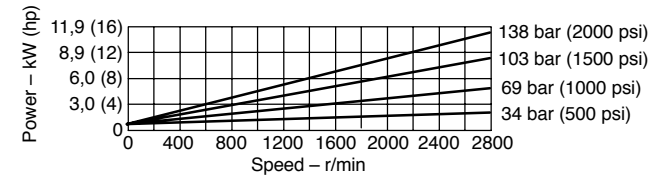
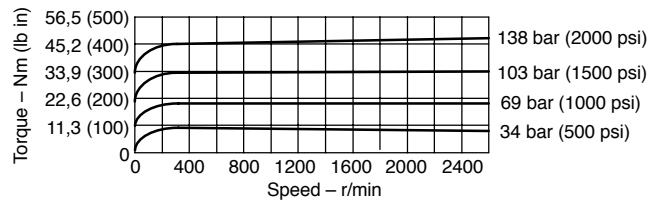
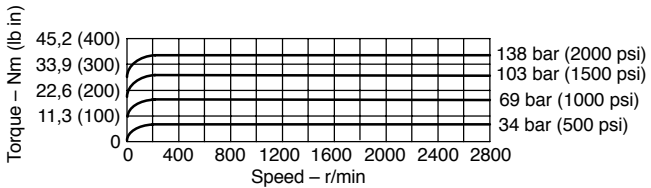
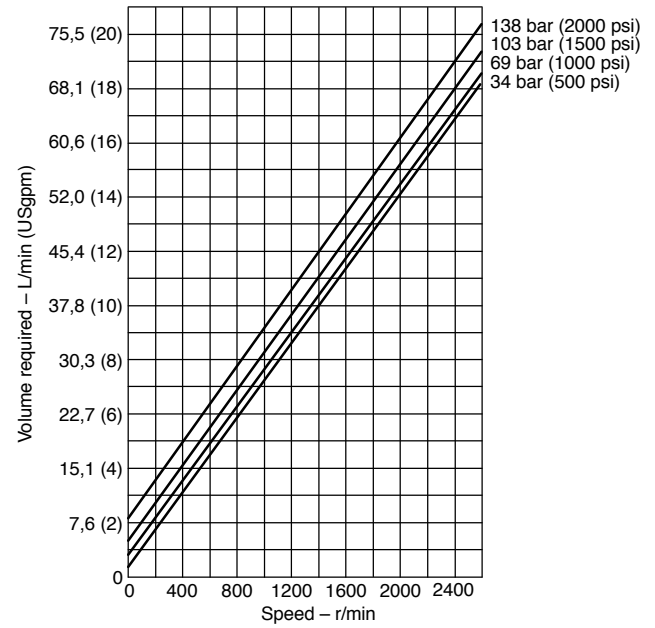

M2U Series

Typical Performance

Performance Constants:
 Oil temp. 49°C (120°F), viscosity
 32 cSt (150 SUS) @ 38°C (100°F)

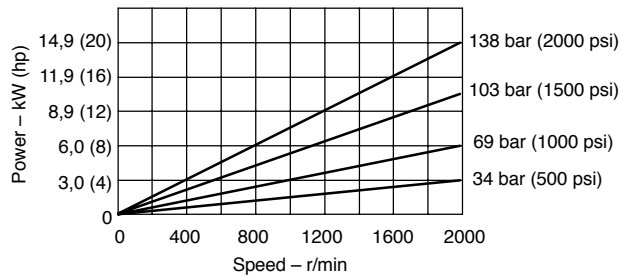
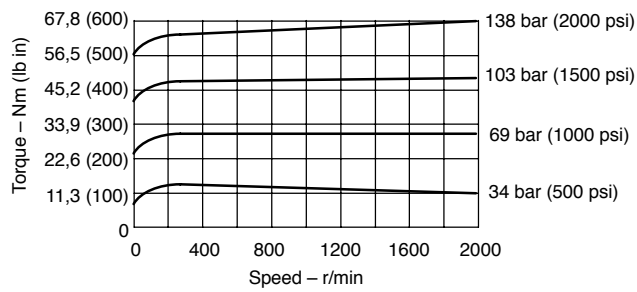
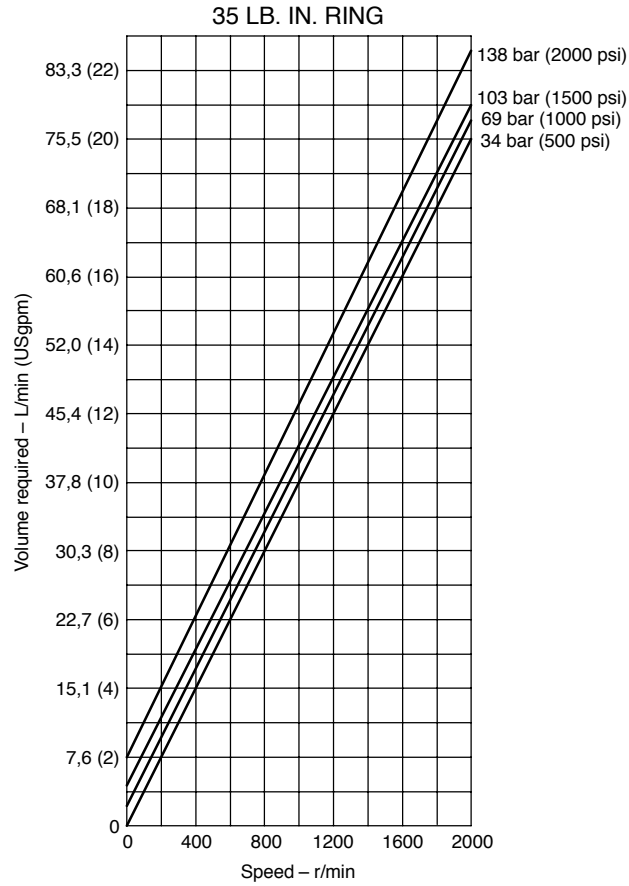

M2-200 Series

Typical Performance

Performance Constants:

Oil temp. 49°C (120°F), viscosity
32 cSt (150 SUS) @ 38°C (100°F)

25 LB. IN. RING

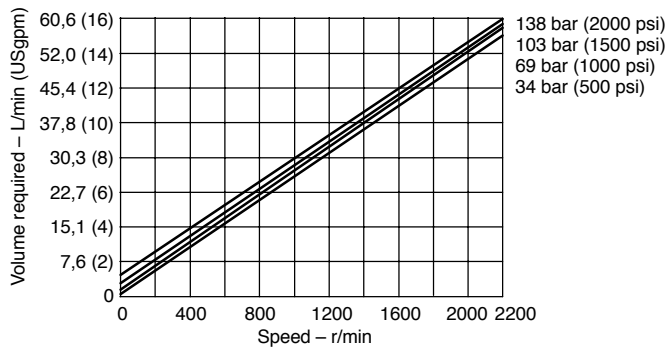

35 LB. IN. RING

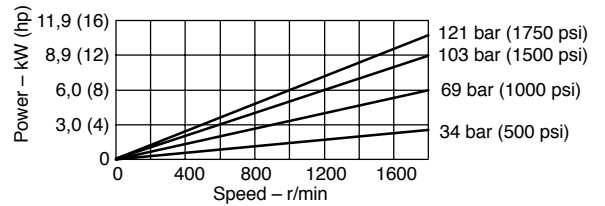
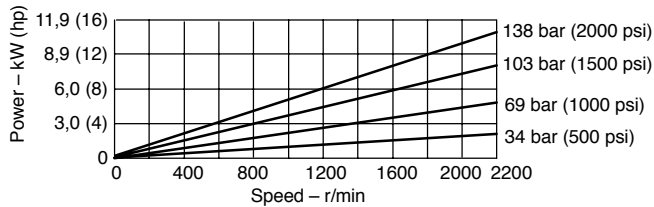
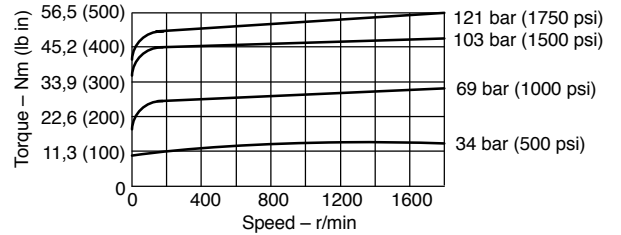
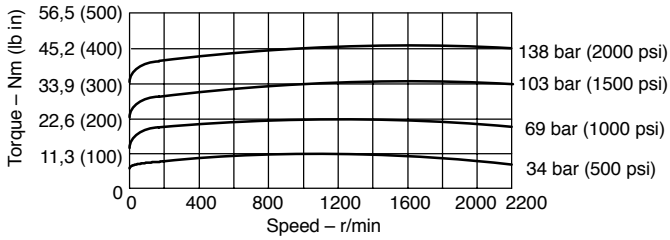
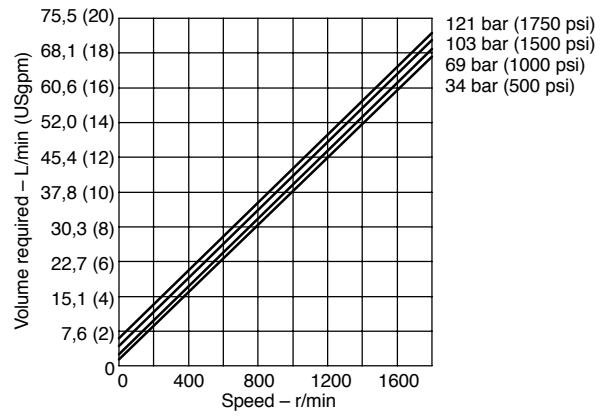

M2U Series

Dimensions in millimeters (inches)

No. 1 shaft shown See options on page 10.

Outlet position "A" shown. See model code, page 4, for other position.

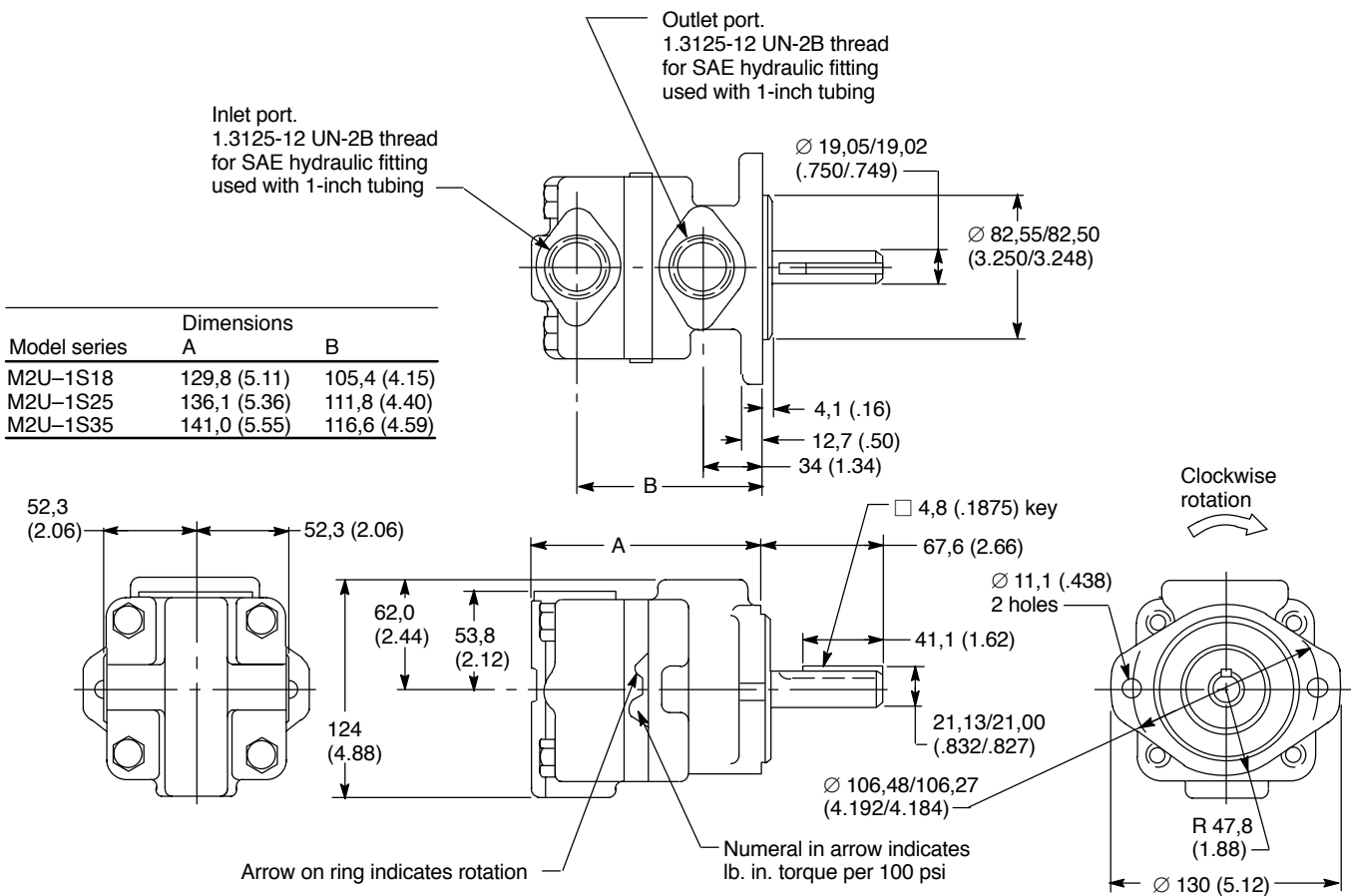

M2-200 Series

Dimensions in millimeters (inches)

Fluid supply to connection "L" provides clockwise shaft rotation, viewed from shaft end. Fluid to connection "K" provides counterclockwise rotation.

No. 1 shaft shown See options on page 10.

Cover position "C" shown. See model code, page 4, for other positions.

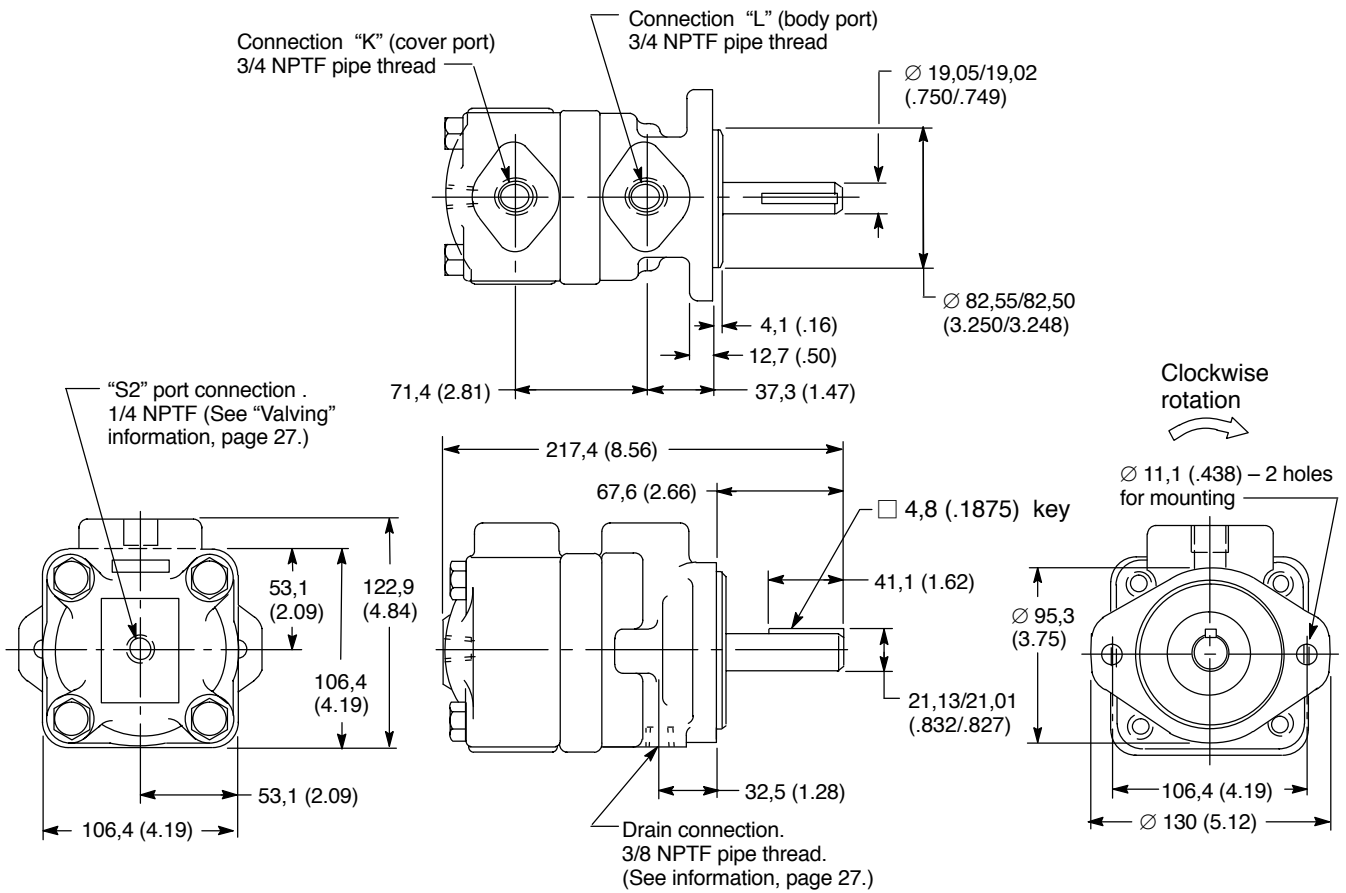

M2U and M2-200 Series

M2U and M2-200 No. 3 Threaded Shaft

See no.1 shaft on pages 8 and 9.

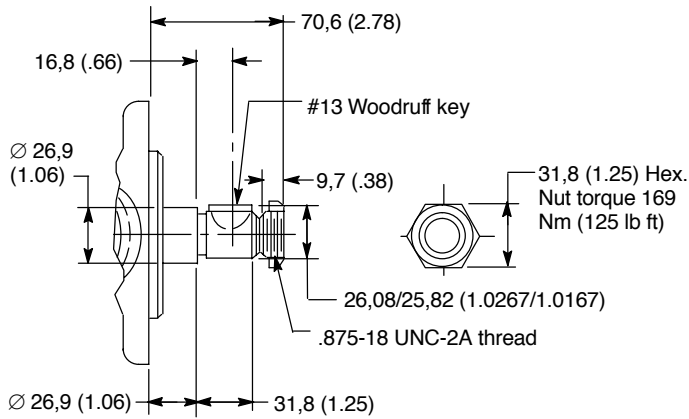

M2U and M2-200 No. 11 Splined Shaft

See no.1 shaft on pages 8 and 9.

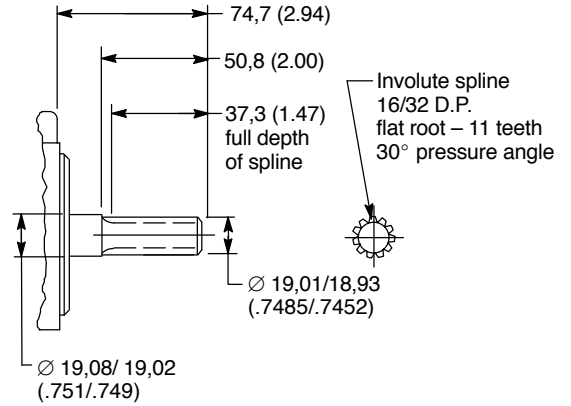

M2-200 No. 6 Straight Stub Shaft

See no.1 shaft on page 9.

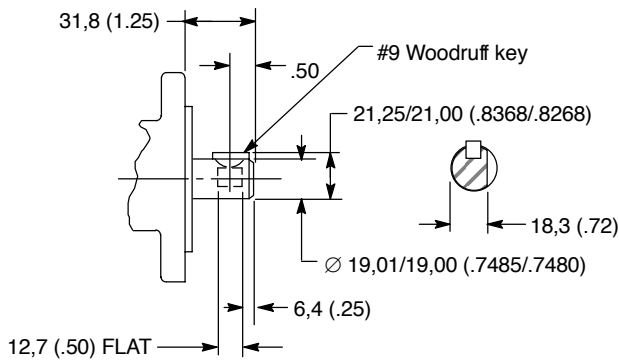

25M-50M Series

Specifications

Model Series	Torque Nm/6,9 bar (lb in/100 psi)	Displacement cm ³ /r (in ³ /r)	Flow input/required @1200 r/min L/min (USgpm)	Maximum speed & pressures	Approx. weight kg (lb)	
25M	4,7 (42)	43,9 (2.68)	52,6 (13.9)	3600 r/min @ 34 bar (500 psi) † 4000 r/min @ 34 bar (500 psi) ‡	18 (40)	
	6,2 (55)	57,7 (3.52)	69,3 (18.3)			
	7,3 (65)	68,7 (4.19)	82,5 (21.8)			
35M	9,0 (80)	83,6 (5.10)	100,3 (26.5)		2600 r/min @ 155 bar (2250 psi) † 3000 r/min @ 172 bar (2500 psi) ‡	29 (64)
	10,7 (95)	100,3 (6.12)	120,4 (31.8)			
	13,0 (115)	121,9 (7.44)	146,1(38.6)			
45M	14,7 (130)	138,0 (8.42)	165,4 (43.7)	2800 r/min @ 34 bar (500 psi) † 3200 r/min @ 34 bar (500 psi) ‡ 2200 r/min @ 155 bar (2250 psi) † 2400 r/min @ 172 bar (2500 psi) ‡●	39 (85)	
	17,5 (155)	163,2 (9.96)	195,7 (51.7)			
	20,9 (185)	193,2(11.79)	232,0 (61.3)			
50M	24,9 (220)	231,2 (14.11)	277,5 (73.3)		73 (160)	
	28,8 (255)	268,1 (16.36)	321,8 (85.0)			
	33,9 (300)	317,1 (19.35)	380,4 (100.5)			

† Continuous operation

‡ Intermittent operation: 10% of total operating time; each application of pressure and/or speed not to exceed 6 seconds

- 114 model suffix: 2500 psi, counterclockwise; 2250 psi, clockwise. (Rotation viewed from shaft end)
- 124 model suffix: 2500 psi, bi-directional rotation

Model Codes

25 M 65 A – 11 C – 20 – ***
1 2 3 4 5 6 7 8

1 Series

25M 35M 45M 50M	} Standard bearing	26M 36M 46M 51M	} Heavy duty bearing
--------------------------	--------------------	--------------------------	----------------------

2 Vane motor

3 Ring size - Nominal torque rating (lb.in./100 psi)

25M: 42, 55 or 65
35M: 80, 95 or 115
45M: 130, 155 or 185
50M: 220, 255 or 300

4 Mounting flange & port connections

A – SAE type 2-bolt mounting flange and SAE 4-bolt flange connections

5 Shaft

1 – Straight keyed
11 – Splined

6 Cover position (Viewing cover end)

A – Cover port opposite body port
B – Cover port 90° CCW from body port
C – Port connections in line
D – Cover port 90° CW from body port

7 Design

Subject to change. Installation dimensions remain the same for designs –20 through –29.

8 Special features suffix

114
124 } 50M only

NOTE: For internal drain, side port, foot mount, case drain, and other options, contact your Vickers representative.

25M Series

Typical Performance

Performance Constants:
 Oil SAE 10W, temperature
 49°C (120°F), viscosity 32 cSt
 (150 SUS) @ 38°C (100°F)

Starting torque is 65%
 (minimum) of 400 r/min torque.

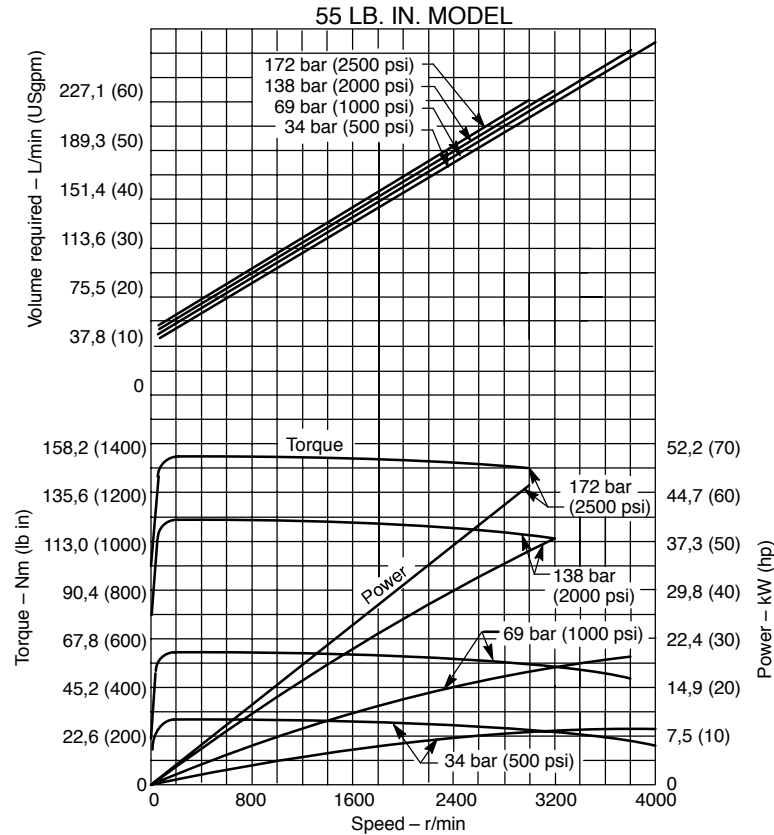
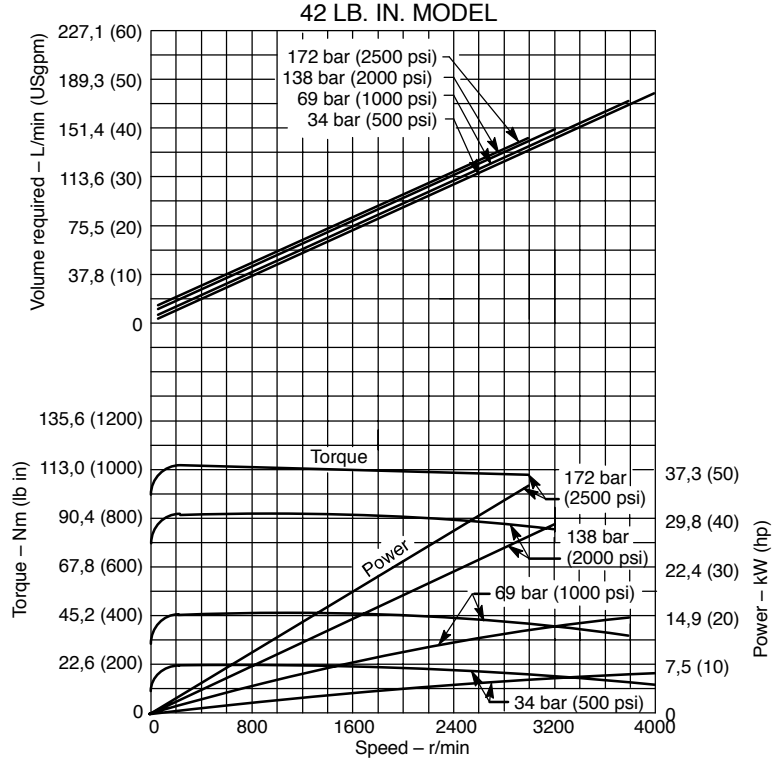

Typical Performance

Performance Constants:
Oil SAE 10W, temperature
49°C (120°F), viscosity 32 cSt
(150 SUS) @ 38°C (100°F)

Starting torque is 65%
(minimum) of 400 r/min torque.

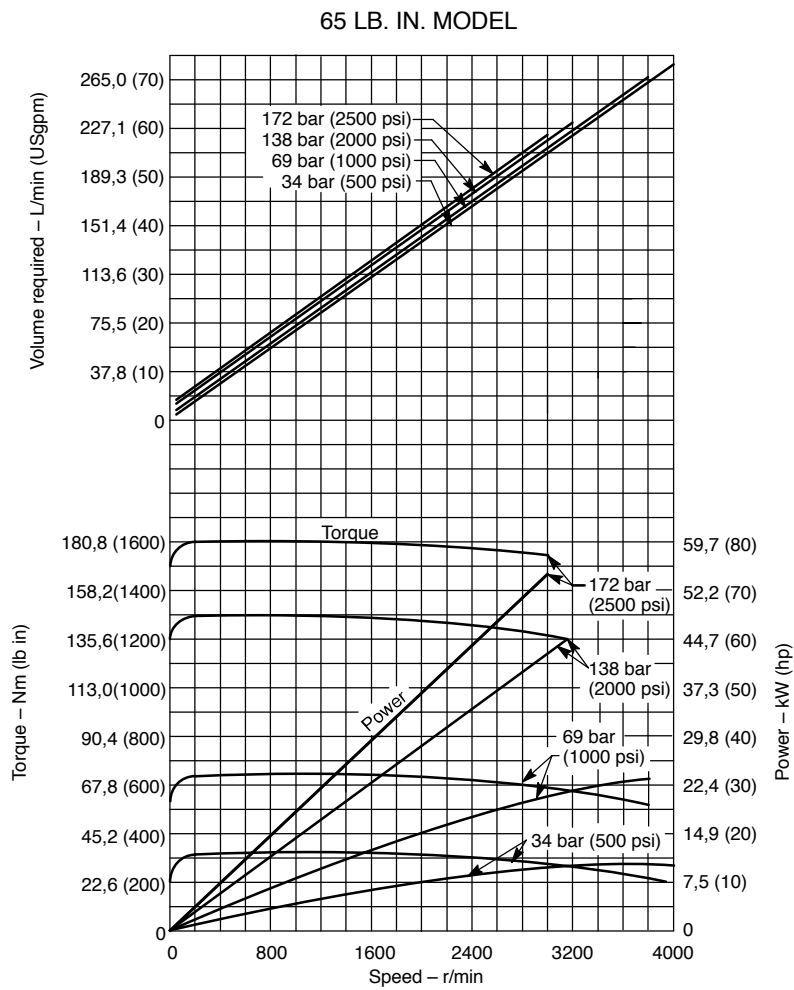

35M Series

Typical Performance

Performance Constants:
 Oil SAE 10W, temperature
 49°C (120°F), viscosity 32 cSt
 (150 SUS) @ 38°C (100°F)

Starting torque is 65%
 (minimum) of 400 r/min torque.

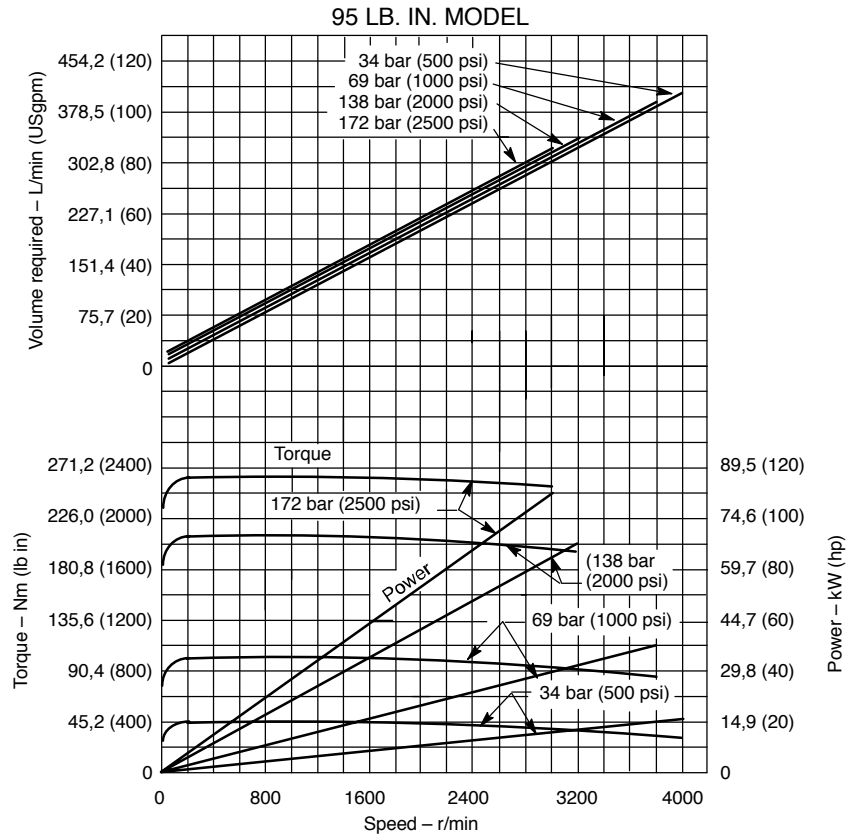
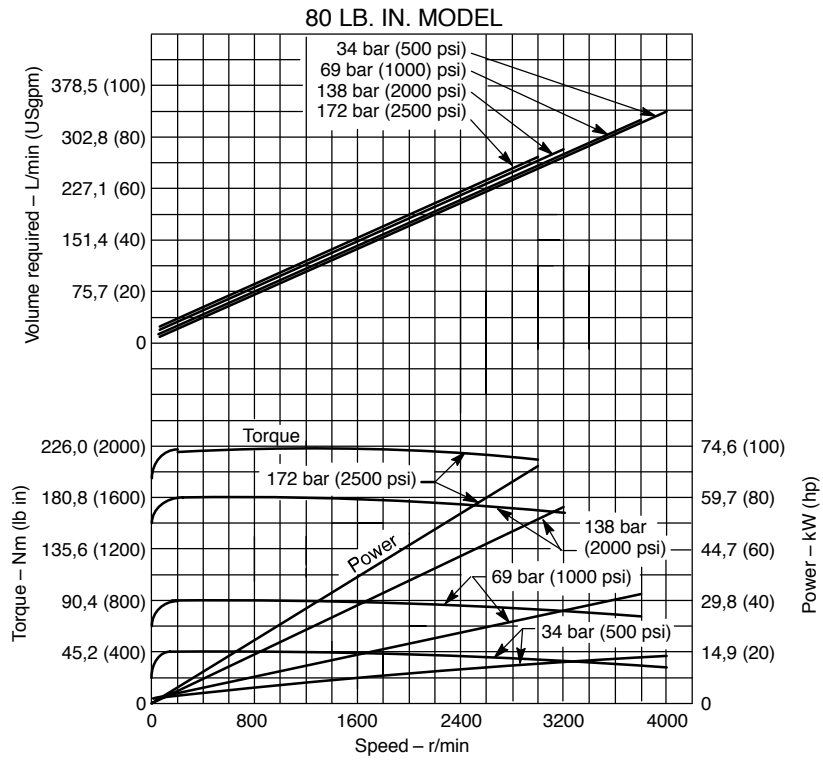

Typical Performance

Performance Constants:
 Oil SAE 10W, temperature
 49°C (120°F), viscosity 32 cSt
 (150 SUS) @ 38°C (100°F)

Starting torque is 65%
 (minimum) of 400 r/min torque

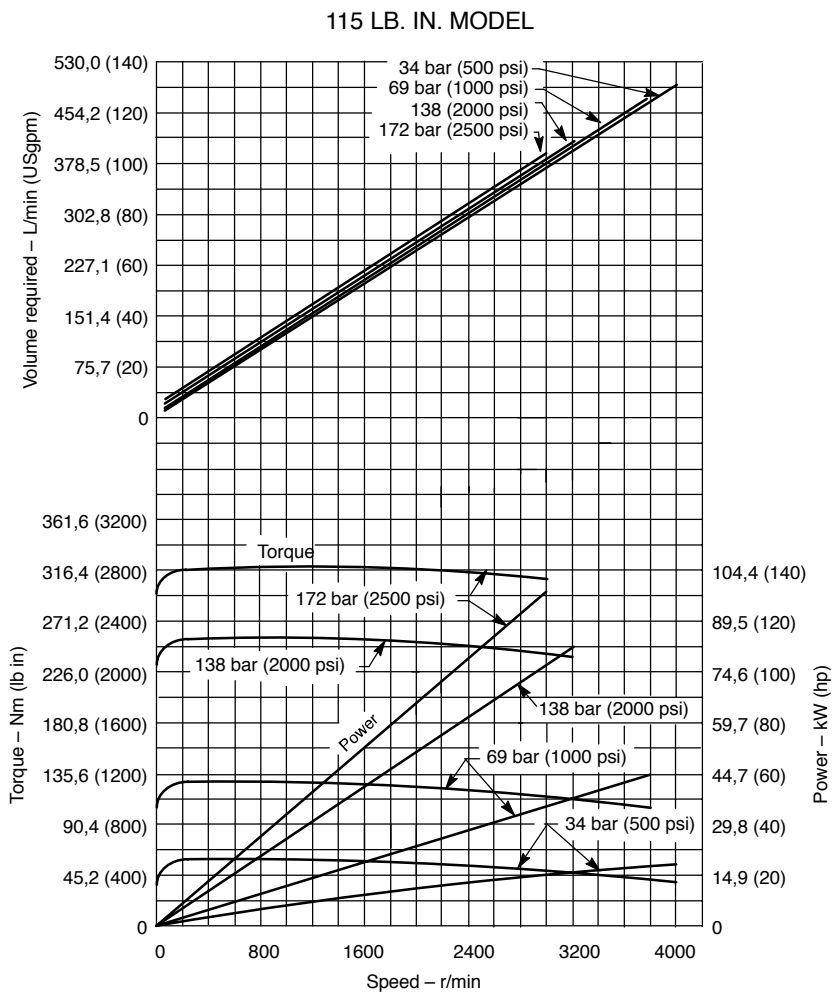

45M Series

Typical Performance

Performance Constants:
 Oil SAE 10W, temperature
 49°C (120°F), viscosity 32 cSt
 (150 SUS) @ 38°C (100°F)

Starting torque is 65%
 (minimum) of 400 r/min torque.

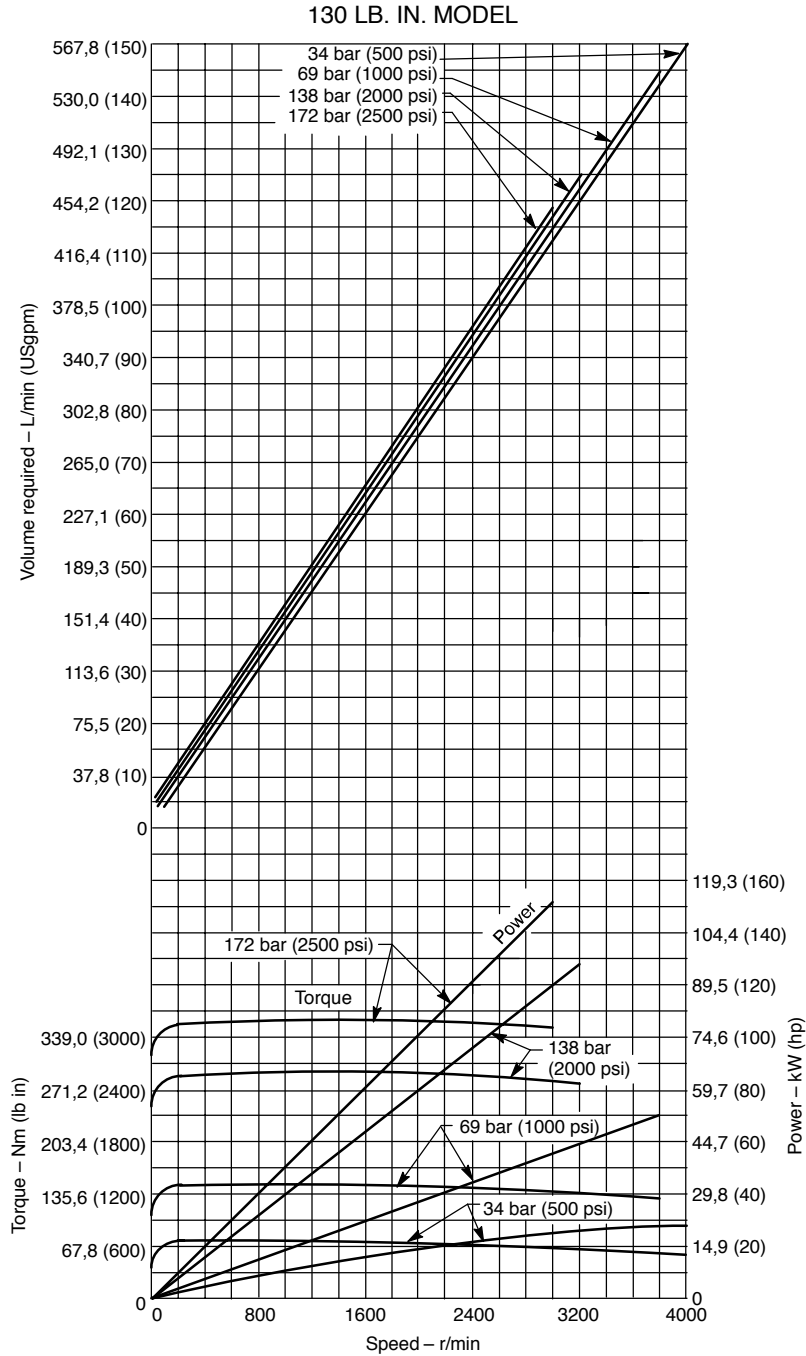

Typical Performance

Performance Constants:
 Oil SAE 10W, temperature
 49°C (120°F), viscosity 32 cSt
 (150 SUS) @ 38°C (100°F)

Starting torque is 65%
 (minimum) of 400 r/min torque.

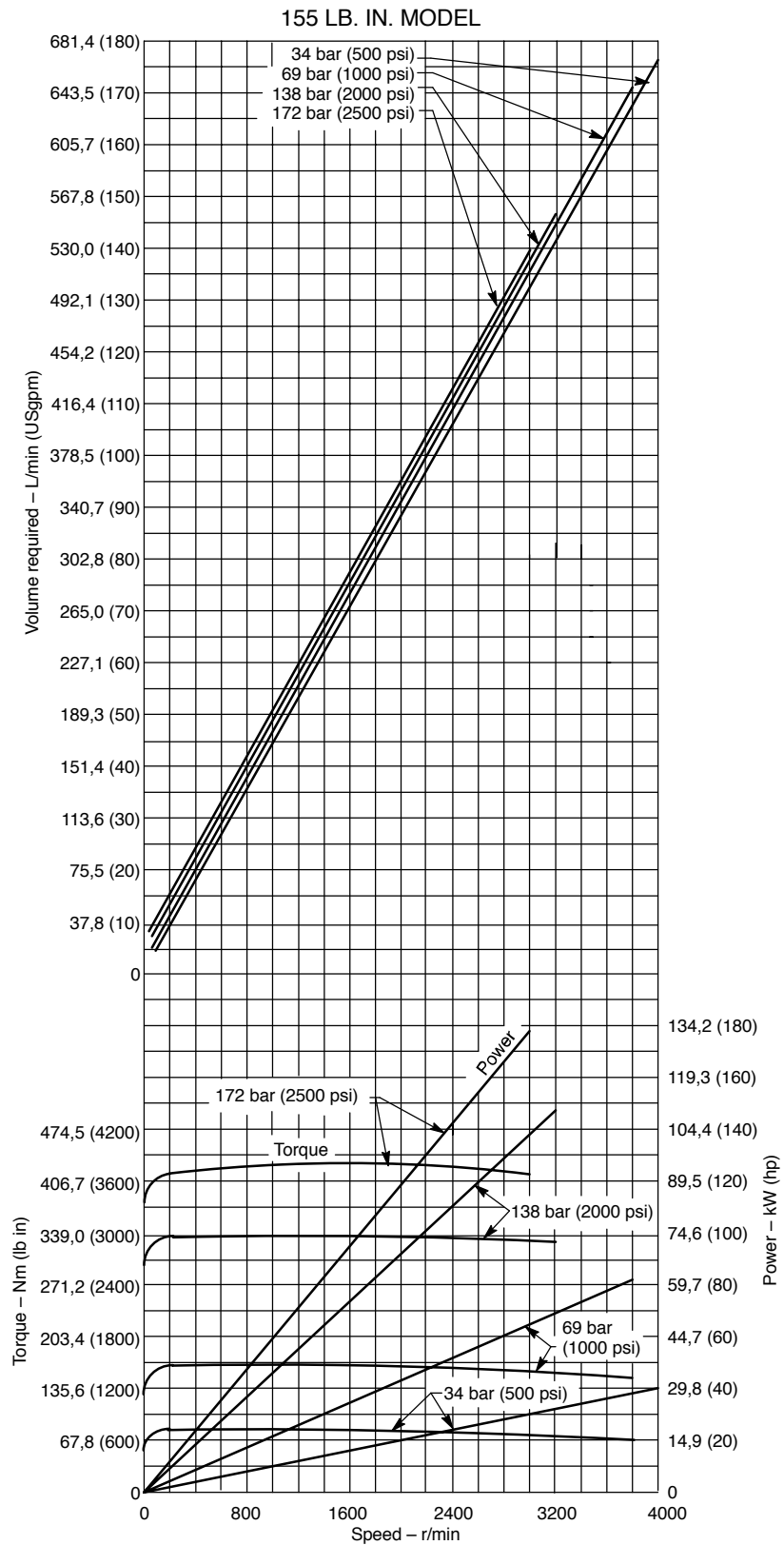

45M Series

Typical Performance

Performance Constants:
 Oil SAE 10W, temperature
 49°C (120°F), viscosity 32 cSt
 (150 SUS) @ 38°C (100°F)

Starting torque is 65%
 (minimum) of 400 r/min torque.

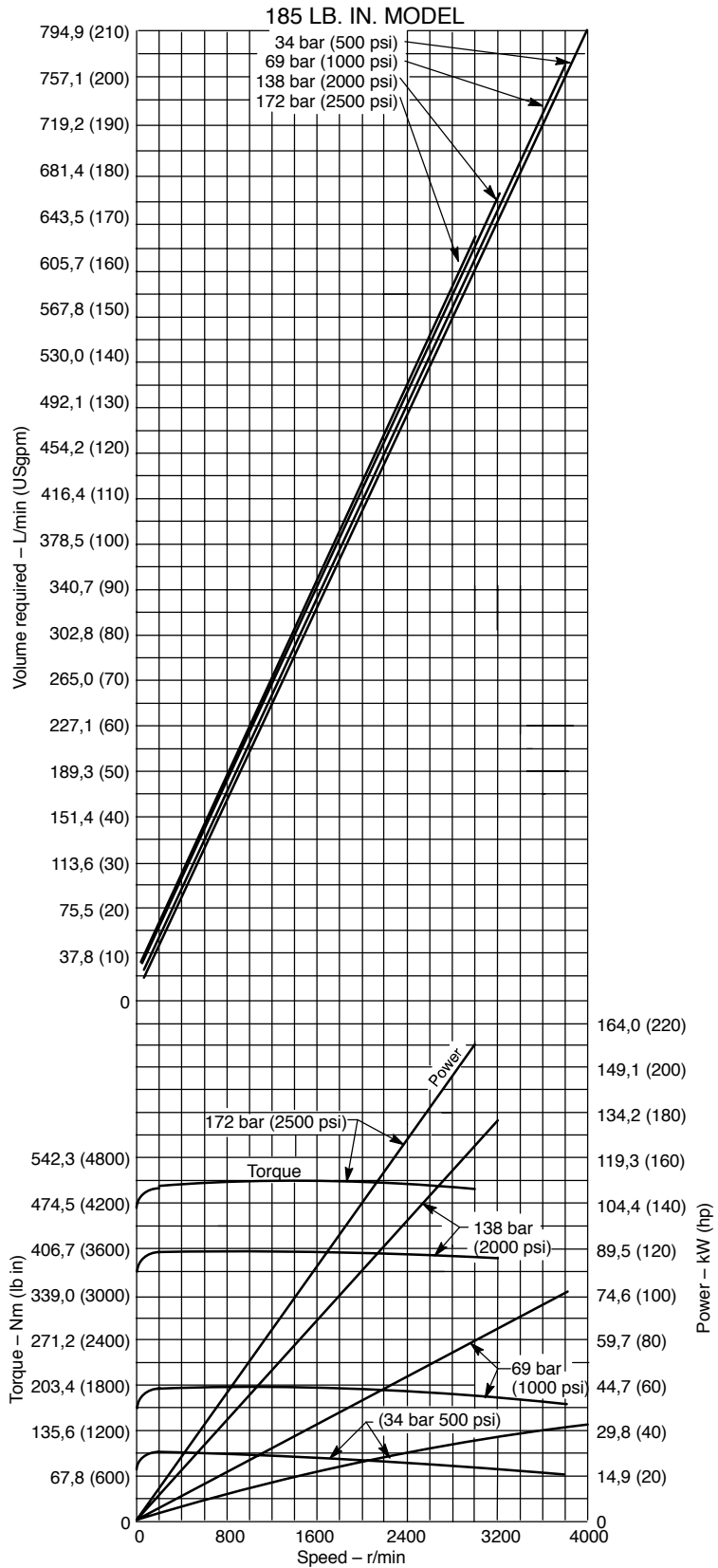

50M Series

Typical Performance

Performance Constants:
 Oil SAE 10W, temperature
 49°C (120°F), viscosity 32 cSt
 (150 SUS) @ 38°C (100°F)

Starting torque is 65%
 (minimum) of 400 r/min torque.

220 LB. IN. MODEL

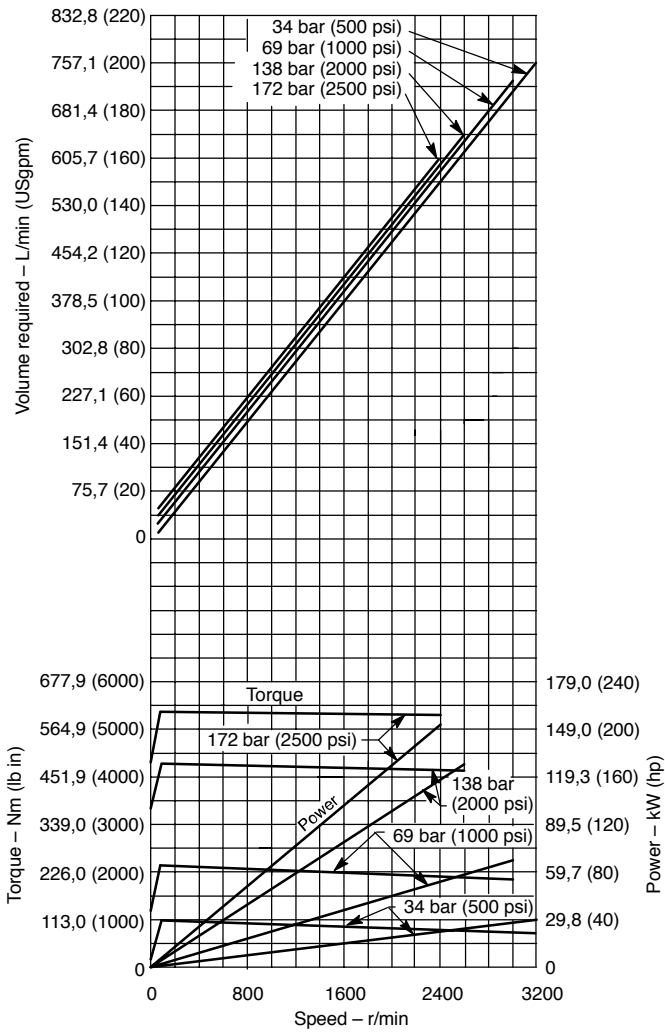

255 LB. IN. MODEL

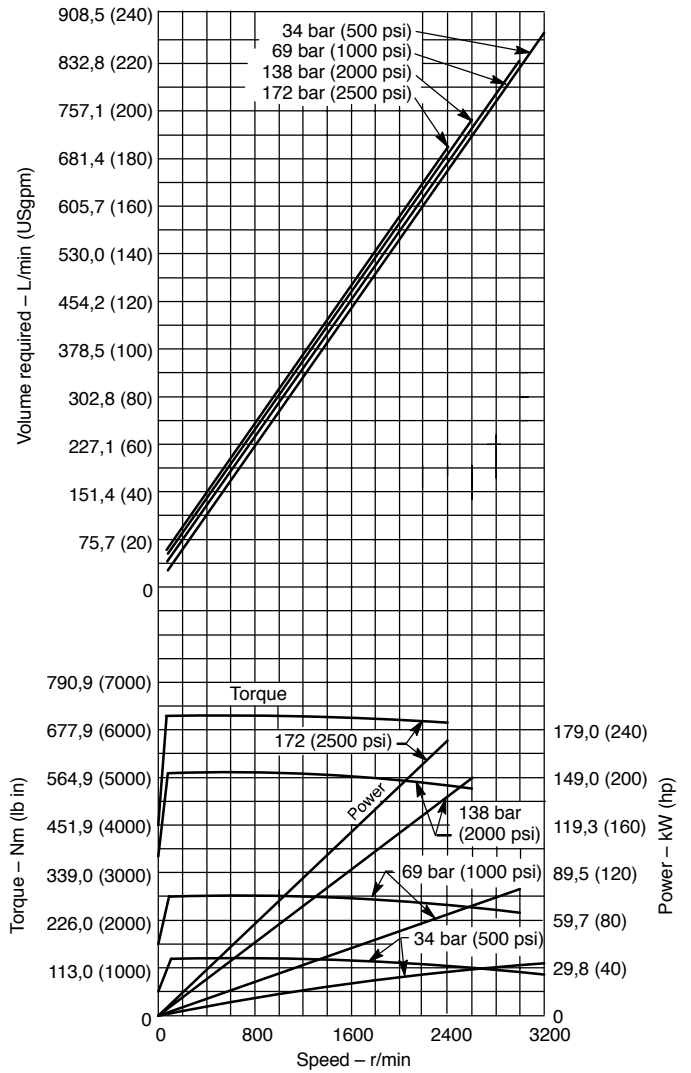

50M Series

Typical Performance

Performance Constants:
 Oil SAE 10W, temperature
 49°C (120°F), viscosity 32 cSt
 (150 SUS) @ 38°C (100°F)

Starting torque is 65%
 (minimum) of 400 r/min torque.

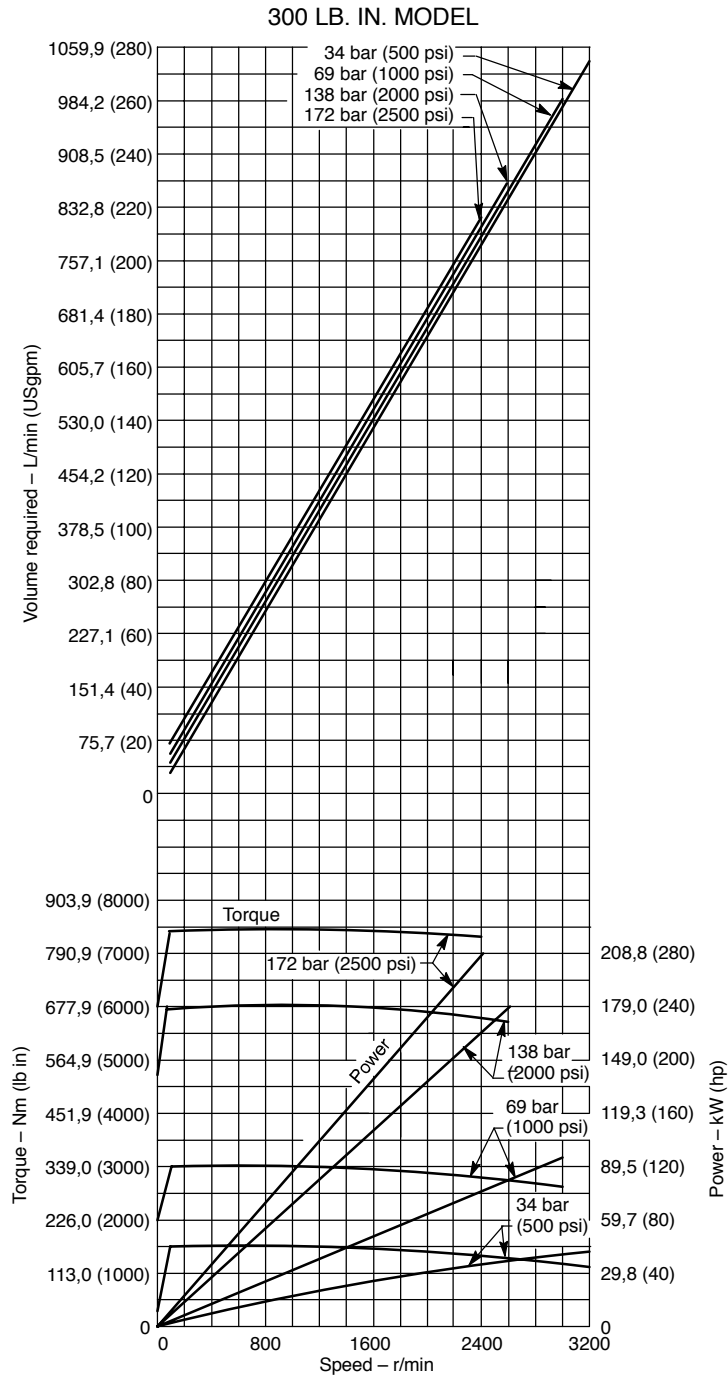

25M Series

Dimensions in millimeters (inches)

Splined shaft shown below. Keyed shaft shown on page 25.

Fluid supply to connection "L" turns shaft clockwise as viewed from shaft end.

Fluid supply to connection "K" turns shaft counterclockwise.

Cover position "C" shown. See model code, page 11, for other positions.

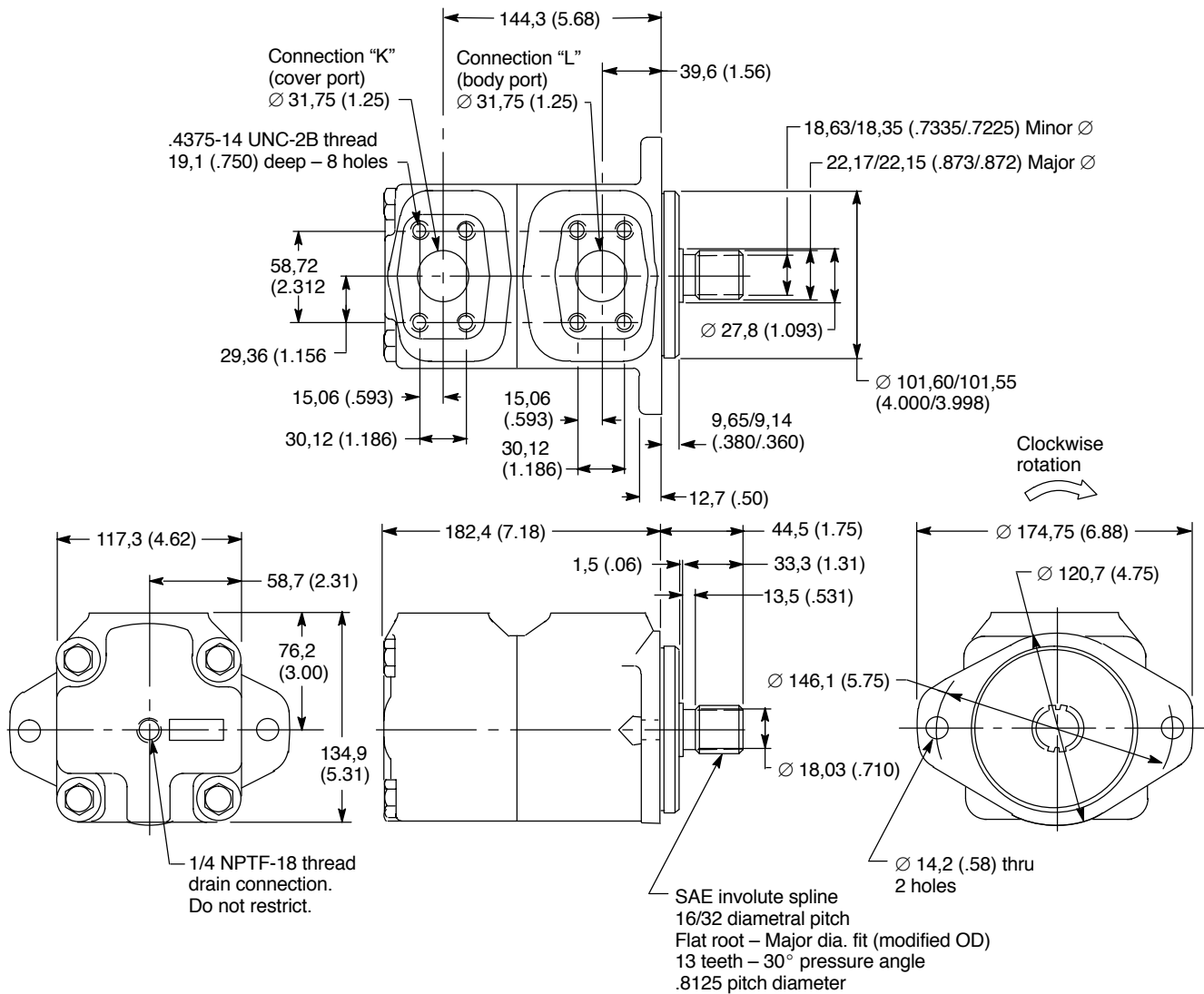

35M Series

Dimensions in millimeters (inches)

Splined shaft shown below. Keyed shaft shown on page 25.

Fluid supply to connection "L" turns shaft clockwise as viewed from shaft end.
 Fluid supply to connection "K" turns shaft counterclockwise.

Cover position "C" shown. See model code, page 11, for other positions.

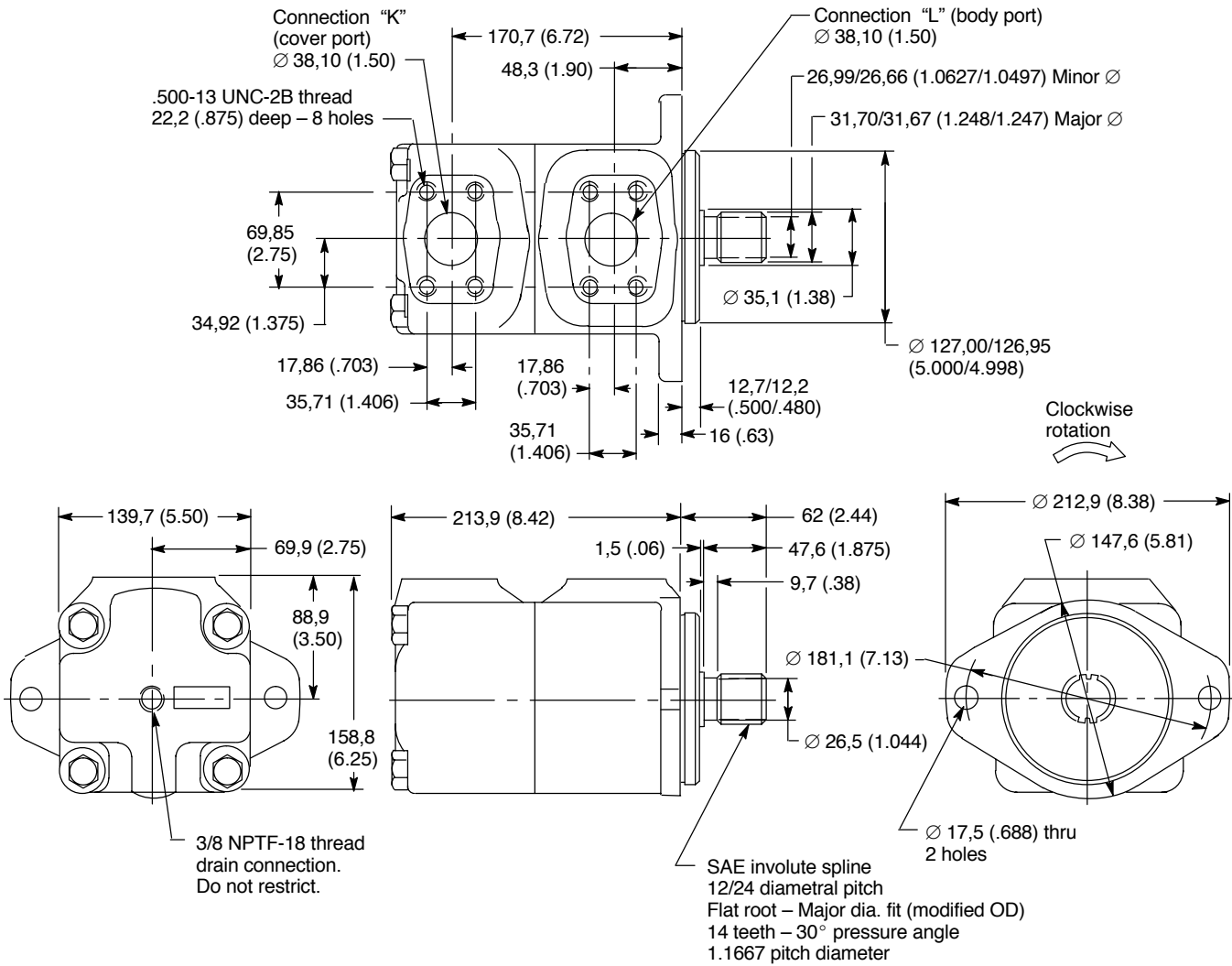

45M Series

Dimensions in millimeters (inches)

Splined shaft shown below. Keyed shaft shown on page 25.

Fluid supply to connection "L" turns shaft clockwise as viewed from shaft end.

Fluid supply to connection "K" turns shaft counterclockwise.

Cover position "C" shown. See model code, page 11, for other positions.

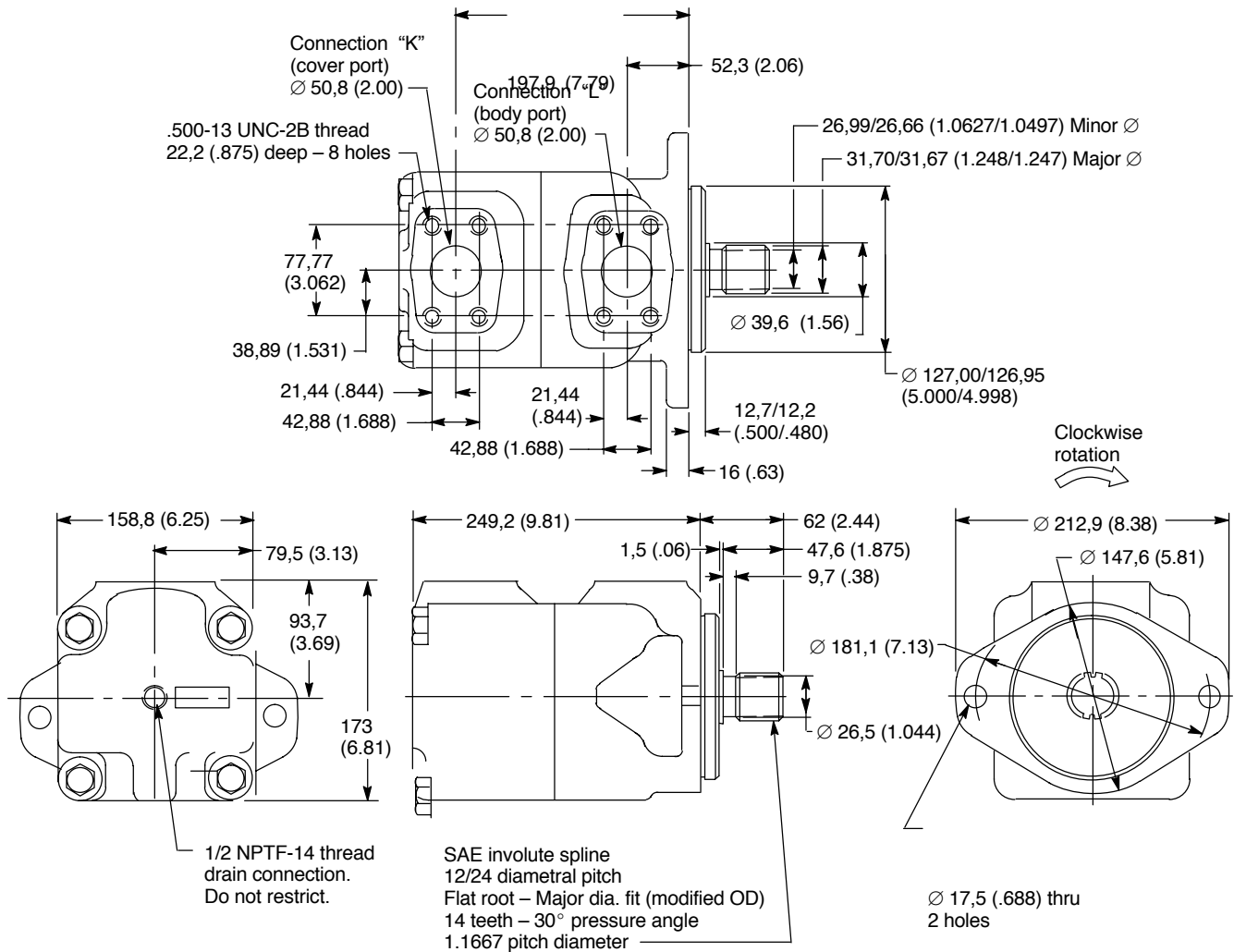

50M Series

Dimensions in millimeters (inches)

Keyed shaft shown on page 25.

Fluid supply to connection "L" turns shaft clockwise as viewed from shaft end.

Fluid supply to connection "K" turns shaft counterclockwise.

Cover position "C" shown. See model code, page 11, for other positions.

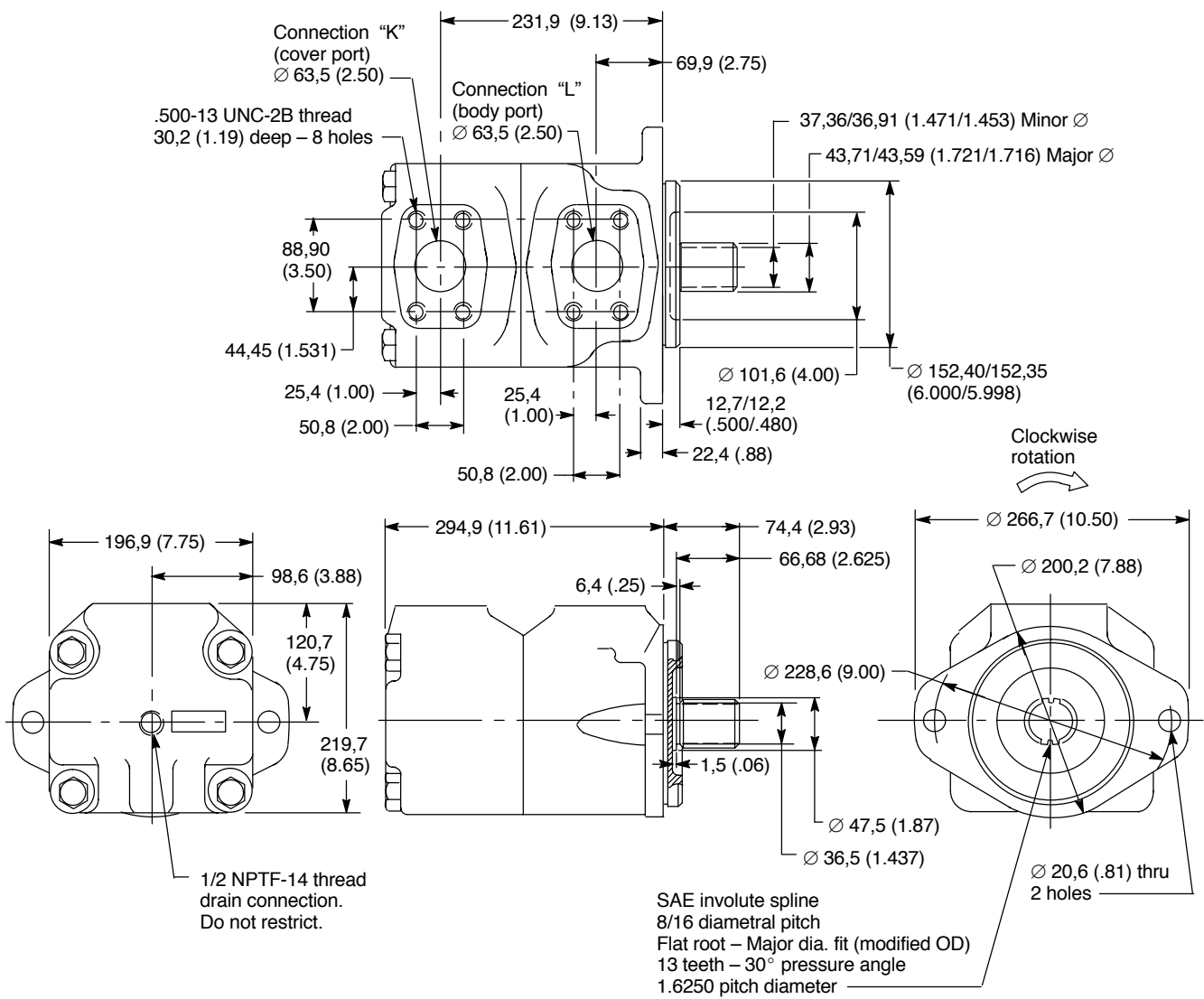

25M-50M Series

25M Series No. 1 Straight-keyed Shaft

See no.11 splined shaft on page 21.

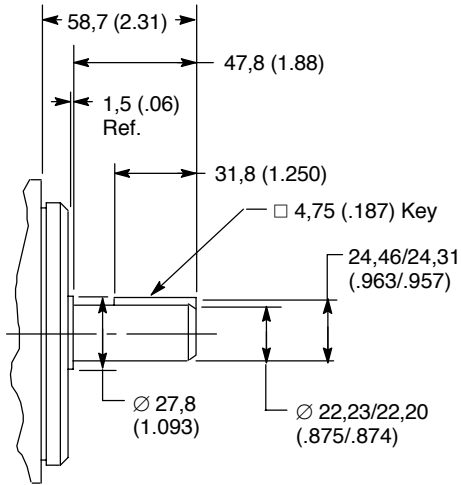

35M and 45M Series No. 1 Straight-keyed Shaft

See no. 11 splined shaft on pages 22 and 23.

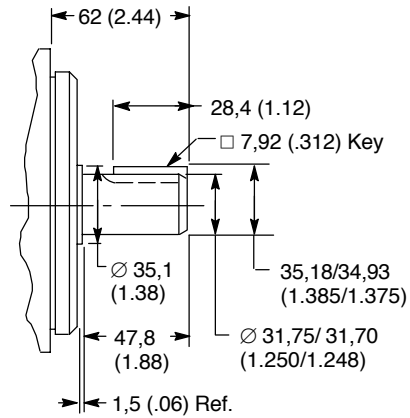

50M Series No. 1 Straight-keyed Shaft

See no. 11 splined shaft on page 24.

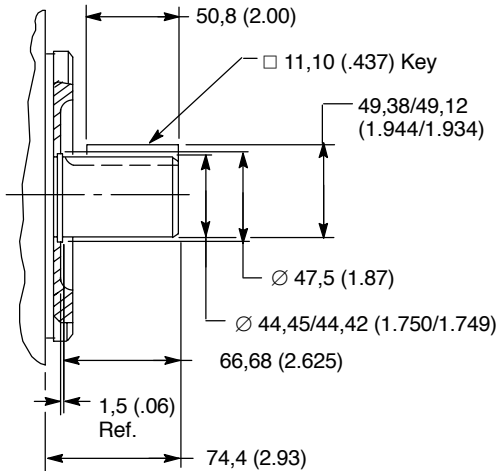

Foot Mounts

The foot bracket kits tabulated below can be used to mount motors having standard SAE-J 744 2-bolt A, B, or C mounting flanges. These designations correspond to -A-, -B-, and -C- letters in the foot bracket kit model number. Each kit includes a bracket and screws for mounting to the motor. Kits are not included with motors and must be ordered separately by model number.

Also available are a bracket (part number 279625) and mounting screws (part number 214794, 2 required) to fit the SAE D mounting flange of 50M motors.

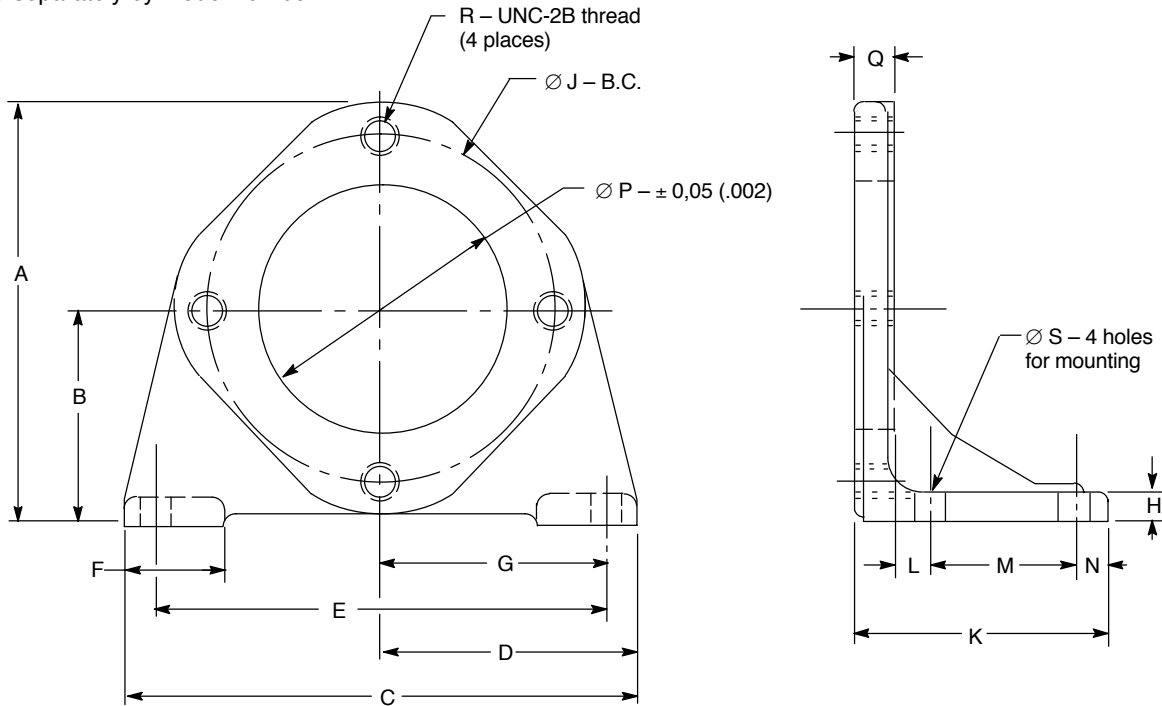

Kit model number	Dimensions							
	A	B	C	D	E	F	G	H
FB-A-10	134,9 (5.31)	69,9 (2.75)	152,4 (6.00)	76,2 (3.00)	127 (5.00)	36,6 (1.44)	63,5 (2.50)	12,7 (.50)
FB-B-10	180,8 (7.12)	92,2 (3.63)	171,5 (6.75)	85,8 (3.38)	146 (5.75)	36,6 (1.44)	73,2 (2.88)	12,7 (.50)
FB-C-10	215,9 (8.50)	109,5 (4.31)	265,2 (10.44)	132,6 (5.22)	235 (9.25)	50,8 (2.00)	117,6 (4.63)	15,7 (.62)

Kit model number	Dimensions								
	Ø J	K	L	M	N	Ø P	Q	R	Ø S
FB-A-10	106,4 (4.19)	96 (3.78)	15 (.59)	50,8 (2.00)	12,7 (.50)	82,63 (3.253)	17,5 (.69)	.38-16	11,2 (.44)
FB-B-10	146 (5.75)	95,8 (3.77)	15 (.59)	50,8 (2.00)	12,7 (.50)	101,68(4.003)	17,3 (.68)	.50-13	17,3 (.68)
FB-C-10	181,1 (7.13)	131,6 (5.18)	19 (.75)	76,2 (3.00)	17,3 (.68)	127,08(5.003)	19 (.75)	.62-11	17,3 (.68)

Application and Service Information

Motor Characteristics

Minimum Operating Speed

Normal speeds can be as low as 50 to 100 r/min for M2U and M2-200 motors, depending upon motor size and characteristics of the driven load.

The minimum speed for 25M - 50M motors is normally 100 r/min. Lower speeds are permissible, depending upon torque requirements and characteristics of the driven load.

Stall Torque

Motor stall torque ranges between 65% and 100% of 1200 r/min running torque for a given pressure differential across the motor. This is dependent on the specific angular position of the shaft at stall and the volume supply of fluid to the motor.

Retarding and Braking

Motors may be used as retarders but not as hydraulic brakes. When a motor is used as a retarder, adequate pressure must be provided at the inlet port to prevent cavitation. Systems requiring positive holding capabilities (braking) must be provided with externally operated mechanical holding devices.

The maximum pressure obtainable in a system using a motor as a retarder (pumping) is dependent upon speed. At speeds below 1000 r/min, maximum obtainable pressure is proportionally diminished relative to speed as speed approaches stall.

Consult your Vickers representative before using motors as retarders, or if braking is required.

Mounting Dimensions

Requirements

Dimensional control requirements of the customer's mounting pad to which the motor is affixed are as follows.

Pilot Diameter

Concentricity of the customer's female pilot diameter relative to the effective axis of the female drive must be within 0,10 mm (.004 in.) total indicator reading. The clearance between the male and female pilot diameters must be +0,01 mm to +0,05 mm (+.0005 to +.0020 inch.)

Mounting Face

The customer's mounting face to which the motor is affixed must be square to the axis of the female drive within 0,04 mm per mm (.0015 inch per inch).

Shafts

Dimensions of keyed shaft receivers must be between +0,003 and +0,03 mm (+.0001 and +.0010 inch) of the maximum shaft diameter shown on the Vickers installation drawing.

Drives

Direct drive through a flexible coupling is recommended but belt, chain or gear drives can be used. Indirect drive applications require approval by Vickers Engineering Department.

Circuitry Requirements

Valving

In the event of acceleration or deceleration of the drive or driven members, overrunning loads or system bleed-off, control valving and circuitry must provide a continuous supply of oil to the motor. This supply should be sufficient to prevent transient or continuous cavitation, but not so large as to result in speeds beyond published maximums.

Protect against hydraulic surge pressures (inlet, outlet or drain) applied to or generated by the motor. Relief valving must prevent surges from exceeding published pressure ratings.

M2-200 Motors (all)

Control valving used with M2-200 motors must have an open center crossover feature to prevent cavitation when the shaft is subject to overrunning loads.

M2-200 Standard Models

Back pressure must not exceed: 75% of supply pressure at 1800 r/min; 80% at 1200; 85% at 600. (Supply and back pressures are actual operating pressures at the ports of the motor.) In circuits where back pressure exists, a relief valve is required in both the inlet and outlet ports.

Consequently, for applications where cavitation, back pressure and/or series type circuits exist, an M2-200 "S2" type motor is recommended.

M2-200 "S2" Models

Pilot pressure must be continuously supplied at the S2 port (page 9) at a level equal to system pressure plus 5,2 bar (75 psi) minimum. This may be obtained by using a check valve in the system supply and with pilot pressure taken from between the pump and this valve.

Piping

Hydraulic lines should be as short and have as large an inside diameter as possible. Where lines are long, it is desirable to adapt to a larger capacity line than a motor's ports specify. Inlet, outlet and drain lines should not be smaller than the nominal port size shown on installation drawings.

There should be as few bends and fittings in lines as possible. High-pressure lines and fittings are restrictive to flow and may result in excessive pressure drop through the system. They should be used only where necessary in a pressure line.

Drain Connection

The case drain line must be full size, unrestricted, and connected from the drain port directly to the reservoir in such a manner that the housing remains filled with fluid. The line must be piped to prevent siphoning and must terminate below the reservoir fluid level. No other lines are to be connected to this drain line.

Pressure surges at the case drain connection may not exceed 1,7 bar (25 psi). Normal pressure is not to exceed 0,7 bar (10 psi). Minimum pressure is zero.

Application and Service Information

Fluids

Fluid Type

Motors can be used with anti-wear hydraulic oil, or automotive type crankcase oil (designations SC, SD, SE, SF, or SG) per SAE J183 JUN89.

Before starting the motor, fill its case with oil. The case must be kept full at all times to provide internal lubrication.

Temperature

Normal operation (at rated conditions) is based on the use of petroleum oil in the 49° to 65°C (120° to 150°F) range. An operating temperature of 49°C (120°F) is recommended.

Normally, temperatures should not exceed 65°C (150°F).

Viscosity

The oil viscosity range with the motor running should be 13-54 cSt (70-250 SUS).

Application Guidance

To ensure optimum motor performance in conjunction with your specific application, consult your Vickers representative if your:

- Oil viscosity at operating temperature is not within 13-54 cSt (70-250 SUS)
- Oil viscosity at startup is in excess of 860 cSt (4000 SUS)
- Operating temperature is not within 38 to 65°C (100 to 150°F). With proper application and fluid consideration, a greater temperature range is permissible.
- System requires fire resistant fluid
- Required minimum speed is less than 100 r/min
- Application has overrunning loads
- Needs require application assistance

Service Information

Refer to the following drawings for service parts information:

Model Series	Drawing
M2U	M-2711-S
M2-200	I-3701-S
25M	M-2741-S
35M	M-2742-S
45M	M-2743-S
50M	M-2744-S

The overhaul manual for M2-200 motors is M-2700-S. The manual for 25M - 50M motors is M-2740-S

Fluid Cleanliness

Proper fluid condition is essential for long and satisfactory life of hydraulic components and systems. Hydraulic fluid must have the correct balance of cleanliness, materials, and additives for protection against wear of components, elevated viscosity, and inclusion of air.

Essential information on the correct methods for treating hydraulic fluid is included in Vickers publication 561 "Vickers Guide to Systemic Contamination Control" available from your local Vickers distributor or by

contacting Vickers, Incorporated. Recommendations on filtration and the selection of products to control fluid condition are included in 561.

Recommended cleanliness levels, using petroleum oil under common conditions, are based on the highest fluid pressure levels in the system and are coded in the chart below. Fluids other than petroleum, severe service cycles, or temperature extremes are cause for adjustment of these cleanliness codes. See Vickers publication 561 for exact details.

Vickers products, as any components, will operate with apparent satisfaction in fluids with higher cleanliness codes than those described. Other manufacturers will often recommend levels above those specified. Experience has shown, however, that life of any hydraulic component is shortened in fluids with higher cleanliness codes than those listed below. These codes have been proven to provide a long, trouble-free service life for the products shown, regardless of the manufacturer.

Product	System Pressure Level bar (psi)		
	<70 (<1000)	70-210 (1000-3000)	210+ (3000+)
Vane Pumps – Fixed	20/18/15	19/17/14	18/16/13
Vane Pumps – Variable	18/16/14	17/15/13	
Piston Pumps – Fixed	19/17/15	18/16/14	17/15/13
Piston Pumps – Variable	18/16/14	17/15/13	16/14/12
Directional Valves	20/18/15	20/18/15	19/17/14
Pressure/Flow Control Valves	19/17/14	19/17/14	19/17/14
CMX Valves	18/16/14	18/16/14	17/15/13
Servo Valves	16/14/11	16/14/11	15/13/10
Proportional Valves	17/15/12	17/15/12	15/13/11
Cylinders	20/18/15	20/18/15	20/18/15
Vane Motors	20/18/15	19/17/14	18/16/13
Axial Piston Motors	19/17/14	18/16/13	17/15/12
Radial Piston Motors	20/18/14	19/17/13	18/16/13